

Owner's Manual

for the

BX-440H / BX-4115



MUSICIAN MADE IN THE U.S.A. by

CRATE

Congratulations!

You are now the proud owner of the innovative Crate BX-440H/BX-4115 ThunderBass amp. These feature-packed powerhouses offer you solid state reliability with classic Crate performance.





Like all Crate products, your BX-440H/BX-4115 ThunderBass amp is Musician Made in the U.S.A., using only the best components. Extensive testing at many stages in its production, including a final “audition” by a skilled musician, insures you that your BX-440H/BX-4115 ThunderBass amp is the best it can be.

In order to get the best possible performance, please read this manual before you use the amplifier.

And **thank you** for choosing .

Contents:

Introduction 3
 Features 3
 The Front Panel 4
 The Rear Panel 5
 Using The Biamp Capabilities: BX-440H . . . 6,7
 Using The Biamp Capabilities: BX-4115 . . . 8,9
 Some Suggested Settings 10
 System Block Diagram 11
 Technical Specifications back cover

 CAUTION RISK OF ELECTRIC SHOCK DO NOT OPEN	 ATTENTION RISQUE D'ELECTROCUTION NE PAS OUVRIR	 VORSICHT ELEKTRISCHE SCHLAGEGFAHR NICHT OFFENEN
CAUTION: TO REDUCE THE RISK OF ELECTRIC SHOCK, DO NOT REMOVE COVER. NO USER-SERVICEABLE PARTS INSIDE. REFER SERVICING TO QUALIFIED SERVICE PERSONNEL.	ATTENTION: POUR REDUIRE D'ELECTROCUTION NE PAS ENLEVER LE COUVERCLE. AUCUNE PIECE INTERNE N'EST REPRABLE PAR L'UTILISATEUR. POUR TOUTE REPARATION, S'ADRESSER A UN TECHNICIEN QUALIFIE.	VORSICHT: ZUR MINIMIERUNG ELEKTRISCHER SCHLAGEGFAHR NICHT DEN DECKEL ABNEHMEN. INTERNE TEILE KONNEN NICHT VOM BENUTZER GEWARTET WERDEN. DIE WARTUNG IS QUALIFIZIERTEM WARTUNGSPERSONAL ZU UBERLASSEN.
THIS EQUIPMENT HAS BEEN DESIGNED AND ENGINEERED TO PROVIDE SAFE AND RELIABLE OPERATION. IN ORDER TO PROLONG THE LIFE OF THE UNIT AND PREVENT ACCIDENTAL DAMAGES OR INJURY, PLEASE FOLLOW THESE PRECAUTIONARY GUIDELINES: CAUTION: TO REDUCE THE RISK OF ELECTRIC SHOCK, DO NOT OPEN CHASSIS; DO NOT DEFEAT OR REMOVE THE GROUND PIN OF THE POWER CORD; CONNECT ONLY TO A PROPERLY GROUNDED AC POWER OUTLET. WARNING: TO REDUCE THE RISK OF FIRE OR ELECTRIC SHOCK, DO NOT EXPOSE THIS EQUIPMENT TO RAIN OR MOISTURE. CAUTION: NO USER-SERVICEABLE PARTS INSIDE. REFER SERVICING TO QUALIFIED SERVICE PERSONNEL. CAUTION: IF YOU USE AUDIO AMPLIFIERS PROFESSIONALLY OR IN WORK RELATED SITUATIONS AS AN EMPLOYEE, THE OCCUPATIONAL SAFETY AND HEALTH ADMINISTRATION (OSHA) HAS SPECIFIED REGULATIONS CONCERNING PROLONGED EXPOSURE TO HIGH SOUND PRESSURE LEVELS. PLEASE REFER TO THE CODE OF FEDERAL REGULATIONS DOCUMENT 29CFR1910 FOR ADDITIONAL INFORMATION.		
EXPLANATION OF GRAPHICAL SYMBOLS:  = "DANGEROUS VOLTAGE" / "DANGER HAUTE TENSION" / "GEFÄHRLICHE SPANNUNG"  = "IT IS NECESSARY FOR THE USER TO REFER TO THE INSTRUCTION MANUAL" / "REFERREZ-VOUS AU MANUAL D'UTILISATION" / "UNBEDINGT IN DER BEDIENUNGSANLEITUNG NACHSCHLAGEN"		

Introduction:

Crate's new BX-440H/BX-4115 ThunderBass amplifiers are feature-packed, professional strength powerhouses which can deliver incredible bass sounds. Rugged construction, reliable American craftsmanship and solid state electronics add up to create very roadworthy, stage-ready gear.

The BX-440H packs solid performance into a compact head unit, contained in a rugged Tolex[®] covered cabinet. Its side-mounted handle and heavy duty rubber feet on two sides increase its value to those musicians who are always "on the go." The BX-4115 combines the same great bass amp with an equally outstanding 15" ThunderBass American-made transducer for a small but hard hitting combo amp suitable for the club, small hall or recording studio.

Both amplifiers will deliver 440 watts into 4 ohms, or 250 watts into 8 ohms. A listing of the features of these amps is given below.

Features:

Additional information can be found on the pages indicated.

- Solid state circuitry for reliable service and incredible tones.
- Crate's APM (Automatic Power Maximizer) limiter circuit for the most output without distortion.
- Variable input gain control with -15dB pad switch and 3 input LEDs for the best match between your bass and the amplifier (page 4).
- Switchable contour control (page 4).
- 8-band graphic equalizer for optimum tone control (page 4).
- Biamp high and low outputs with adjustable crossover frequency and low-to-high balance (page 4).
- Switchable chorus with adjustable spectrum, rate and depth controls (BX-4115 only) (page 4).
- Balanced line out with adjustable level control and "pre/post" switch (pages 4 and 5).
- Headphone jack with adjustable level control for private practice sessions (page 4).
- Effects loop for noiseless use of your favorite processors and effects (page 5).
- Rugged Tolex[®] covered cabinets for durability with nickel and chrome accents for high cosmetic appeal.
- Removable heavy duty casters for ease of transportation (BX-4115 only).
- Musician made in the U.S.A.
- Crate's exclusive 5-year warranty (U.S. only). Outside U.S. see local dealer for warranty terms and information.

The Front Panel:

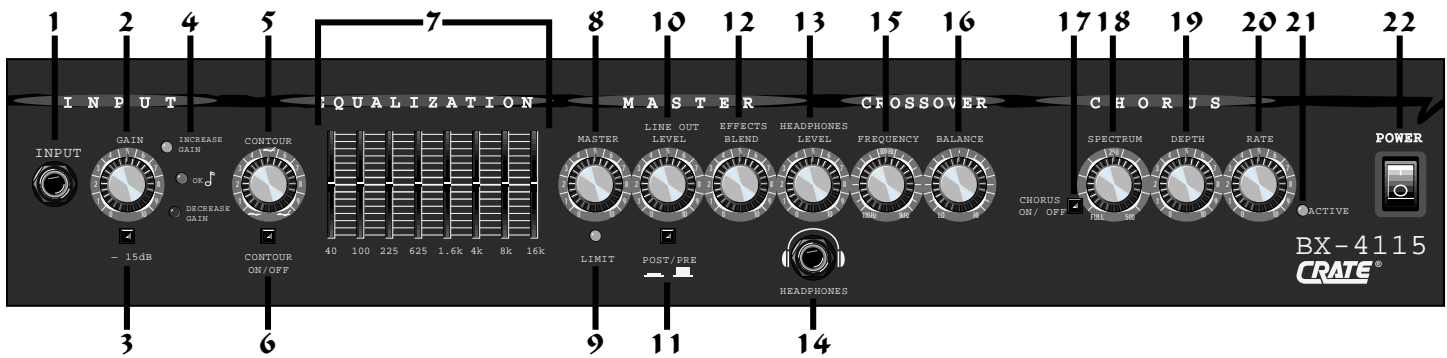

1. INPUT: Connect your bass to the amplifier here.

2. GAIN: Use this control to properly match the output of your bass to the amplifier. With the amp's Master level control at "0", begin playing your bass as you normally would. Watch the adjacent LEDs (#4) as you turn up the Gain control: the proper setting for the Gain control is the one where the "OK" LED lights most often while playing. If the "Decrease Gain" LED stays lit even with the Gain control turned down low, press in the -15dB button (#3) and continue adjusting the Gain control until the proper setting is obtained.

3. -15dB: If your bass has active electronics or "hot" pickups, its output signal may need to be padded to get the best signal to noise setting from the Gain control. If the "Decrease Gain" LED stays lit with the Gain control turned down low, press in the -15dB button.

4. LEDs: These three LEDs are your guide to properly setting the Gain control. Follow the steps given for the Gain control (#2) until the "OK" LED lights most often while you play.

5. CONTOUR: This control allows you to make additional changes to your tone and is active only when the Contour On/Off switch (#6) is pressed in. As the "wave" icons indicate you can enhance both the lows and highs at the same time, or add mid punch.

6. CONTOUR ON/OFF: Use this switch to engage the contour circuitry. With the switch pressed in, the Contour control (#5) is active.

7. EQUALIZATION: This eight-band graphic equalizer allows you to custom tailor your tone. Each slider controls the frequency indicated directly below it and offers a cut or boost of 10dB at various frequencies from 40Hz to 16kHz

8. MASTER LEVEL: Use this control to set the output level of the amplifier. This controls the signal level at the Speaker Output jacks (#30), as well as the Preamp Out jack (#28).

9. LIMIT: The amplifier employs Crate's APM Automatic Power Maximizer protection circuitry to keep the output distortion-free even at high volume levels. Whenever the output nears its clipping point, the limit circuit kicks in to keep the output clean. The Limit LED lights up when the APM limiter circuit is activated. Occasional flashing of the LED is normal. Very frequent flashing or constant illumination indicates the output level is too high; reduce the Master level control (#8) and/or your instrument's output until the LED flashes less.

10. LINE OUT LEVEL: This controls the level of the signal at the Balanced Line Out jack (#31). You may also use this output (or the headphone jack, #14) to run a signal to a tuner.

11. POST/PRE: This switch selects the tap point for the signal at the Balanced Line Out jack. With the switch out, the signal is tapped *before* the eq, contour and effects loop ("pre"). With the switch pressed in, the signal is tapped *after* the eq, contour and effects loop ("post").

12. EFFECTS BLEND: This control proportions the amount of effect added to the signal going to the power amp stage. At the "0" position the signal is "dry" (no effect added); as you bring the control towards "10" the amount of effect applied increases. ("5" is a 50/50 blend of dry signal and effects.)

13. HEADPHONES LEVEL: This control adjusts the signal level at the Headphones jack (#14).

14. HEADPHONES: Plug a pair of stereo headphones in here for private listening. The signal at this jack is post Gain and post EQ. The level of the signal here is determined by the set-

ting of the Headphones Level control (#13). Using headphones does not disable the speaker outputs or the internal speaker (BX-4115). You may also use this output (or the line out jack, #31) to run a signal to a tuner.

15. FREQUENCY: This sets the crossover point when using the amplifier in the biamp mode (using two power amplifiers, one for the low frequencies, one for the highs). Please see the section entitled "Using the Biamp Capabilities" on pages 6 - 9 for more details about biamping.

16. BALANCE: This adjusts the relative level between the low frequency and the high frequency biamp output signals. Please see the section entitled "Using the Biamp Capabilities" on pages 6 - 9 for more details.

17-21, Chorus Section, BX-4115 Only:

17. CHORUS ON/OFF: This switch turns the Chorus section on when pressed in, off when switched out.

18. SPECTRUM: This control allows you to adjust which frequencies (from the entire range to only above 500Hz) are enhanced by the chorus effect. The further to the left (toward "Full") you turn the control the broader the spectrum of the chorus effect.

19. DEPTH: This control sets the amount of chorus enhancement: towards "0" for less, towards "10" for more.

20. RATE: This control sets the speed for the chorus effect: towards "0" for slower, towards "10" for faster.

21. ACTIVE: This LED lights when the chorus effect is engaged. The LED pulses in relation to the rate of the chorus.

22. POWER: This two-position switch turns the amp on and off, "on" being the UP position. The switch lights up when the amp is turned on.

The Rear Panel:

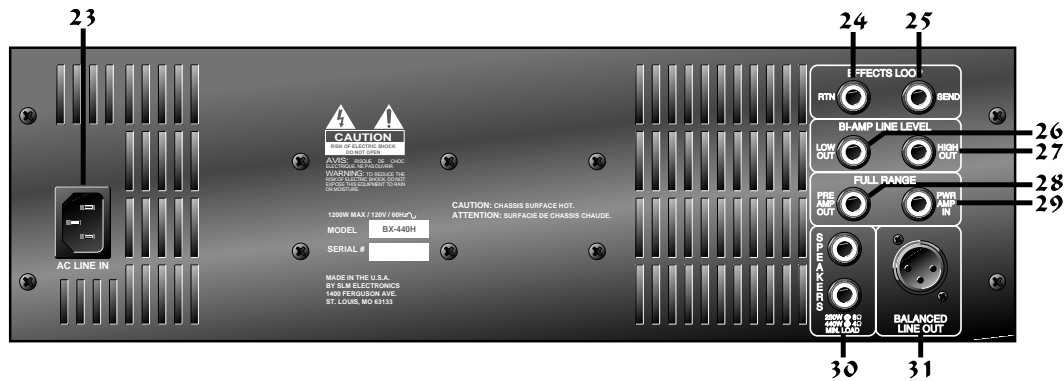

23. POWER CORD: Connect the male end of this cord to a properly grounded AC power outlet. **Use only a grounded outlet! DO NOT defeat the ground pin of the cord!** If the amplifier is used outside of the United States, see the area's Crate dealer for the proper power cord or consult a local professional electrician.

24. EFFECTS LOOP RETURN: When using an external signal processor, the best results will be obtained when the device is connected to the amplifier's effects loop for virtually noise-free operation. This jack receives the output signal from such a processor

25. EFFECTS LOOP SEND: This unbalanced jack lets you send a signal out to an external effects processor or tuner. The signal at this jack is post-EQ, pre-Master. Connect this to the input jack of the processor or tuner. Use shielded cables with mono 1/4" plugs for connecting the Effects Loop.

26. BIAMP LOW OUT: When used in the biamp mode, this output connects to the low frequency power amplifier. See the section entitled "Using the Biamp Capabilities" on pages 6 - 9 for details.

27. BIAMP HIGH OUT: When used in the biamp mode, this output connects to the high frequency power amplifier. See the section entitled "Using the Biamp Capabilities" on pages 6 - 9 for details.

28. PREAMP OUT: A pre-amplified line level signal may be tapped from this jack for sending to an external amplifier, powered monitor, recording console, mixing board or effects processor. This is an unbalanced, mono 1/4" jack.

29. POWER AMP IN: A pre-amplified line level signal may be sent directly into the bass amp's power amp (as when slaving two amplifiers together, for example). Connection to this jack interrupts the signal from the internal preamp to the power amp. The Preamp Out (#28) signal is **not** interrupted.

30. SPEAKERS: Use these jacks to connect the amp to your speaker cabinet(s). Use heavy duty speaker cables with mono 1/4" plugs. These jacks are wired in parallel. Don't use cabinet combinations resulting in impedance loads below 4 ohms. Use the following chart to help determine parallel loads. If in doubt, ask your dealer.

<u>Cab Imp.</u>	<u># Cabs</u>	<u>Total Imp.</u>
8 ohms	2	4 ohms
16 ohms	2	8 ohms
16 ohms	4	4 ohms

31. BALANCED LINE OUT: Use this 3-pin XLR jack to send a line level signal to the house sound board or mixing console. The level of the signal at this jack is determined by the setting of the Line Out Level control on the front panel (#10). This signal is switchable to be either pre or post EQ through the front panel Pre/Post switch(#11).

Using the Biamp Capabilities – BX-440H:

About Biamping: The Biamp High and Low outputs of the BX-440H and the BX-4115 allow for a number of ways to “biamp” your system: that is, using two amplifier/speaker combinations to share the task of reproducing the full range of your bass. Biamping increases each amplifier’s efficiency by allowing it to “focus” on a certain frequency range, rather than operating full range. The results of biamping include cleaner sound and more output power than that of a single-amped system, which is especially useful during high volume live performances.

There are a number of different ways to use the BX-440H and the BX-4115 in biamp configurations. The examples on the following pages show several biamp possibilities – you may find others. Your Crate dealer can assist you in assembling the custom biamp ThunderBass rig to best suit your playing style and venue.

The Biamp Controls: The front panel Crossover Frequency control (#15) sets the point where the low frequency signal rolls off and the high frequency signal begins. This control is variable from 100Hz to 1kHz. Adjust this control to best suit the frequency range of your low frequency speaker cabinet. The Crossover Balance control (#16) proportions the signal between the high and the low output jacks (#26 and 27, rear panel). Adjust this control for the most appealing blend of lows and highs.

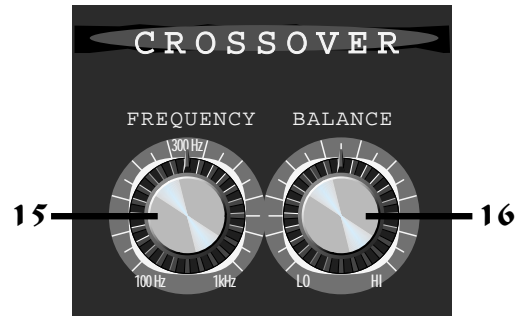

Example 1:

With the BX-440H and a BXE-18 cabinet for the low end; a BX-220H and a BXE-410H cabinet for the high end:

Plug your bass into the BX-440H, then:
 (1) Run a shielded cable from the **biamp high out** jack of the BX-440H to the **power amp in** jack of the BX-220H.

(2) Run a speaker cable from the **speaker out** jack of the BX-220H to the **input** jack of the BXE-410H.

(3) Run a shielded cable from the **biamp low out** jack of the BX-440H to its **power amp in** jack.

(4) Run a speaker cable from the **speaker out** jack of the BX-440H to the **direct in** jack of the BXE-18.

Adjust the Crossover Frequency and Balance controls for the best sound.

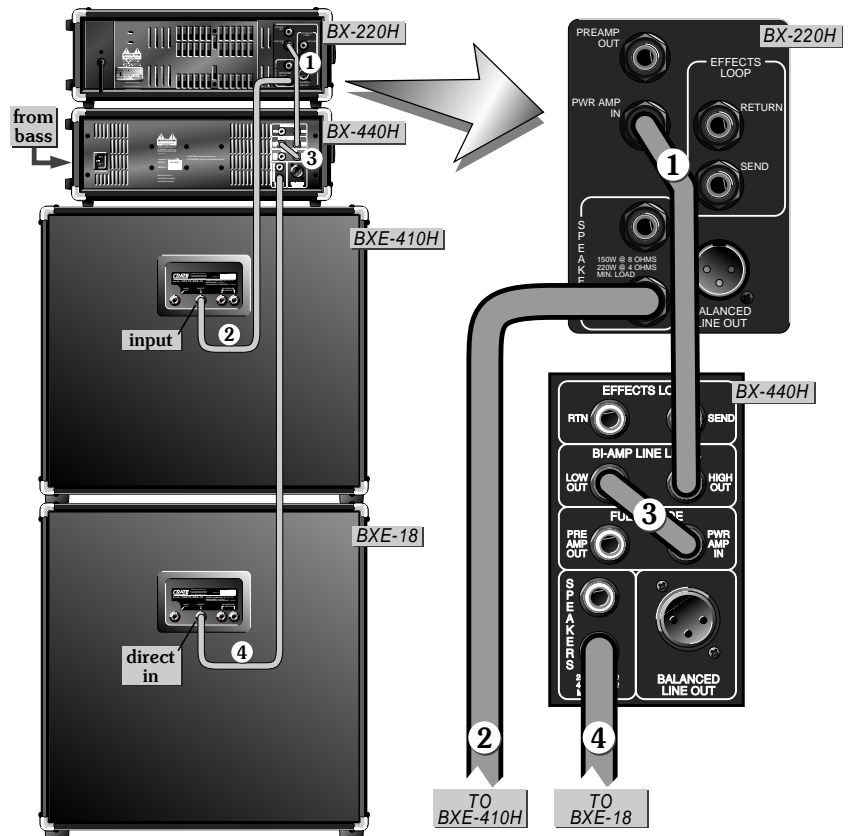

Using the Biamp Capabilities – BX-440H (con't):

Example 2:

With the BX-440H and a BXE-410H cabinet for the high end; a mono (or mono-bridged) power amp and a BXE-18 cabinet for the low end:

Plug your bass into the BX-440H, then:

- (1) Run a shielded cable from the **biamp high out** jack of the BX-440H to its **power amp in** jack.
- (2) Run a speaker cable from the **speaker out** jack of the BX-440H to the **input** jack of the BXE-410H.
- (3) Run a shielded cable from the **biamp low out** jack of the BX-440H to the **input** jack of the mono power amp.
- (4) Run a speaker cable from the **speaker out** jack of the mono power amp to the **direct in** jack of the BXE-18.

Adjust the Crossover Frequency and Balance controls for the best sound.

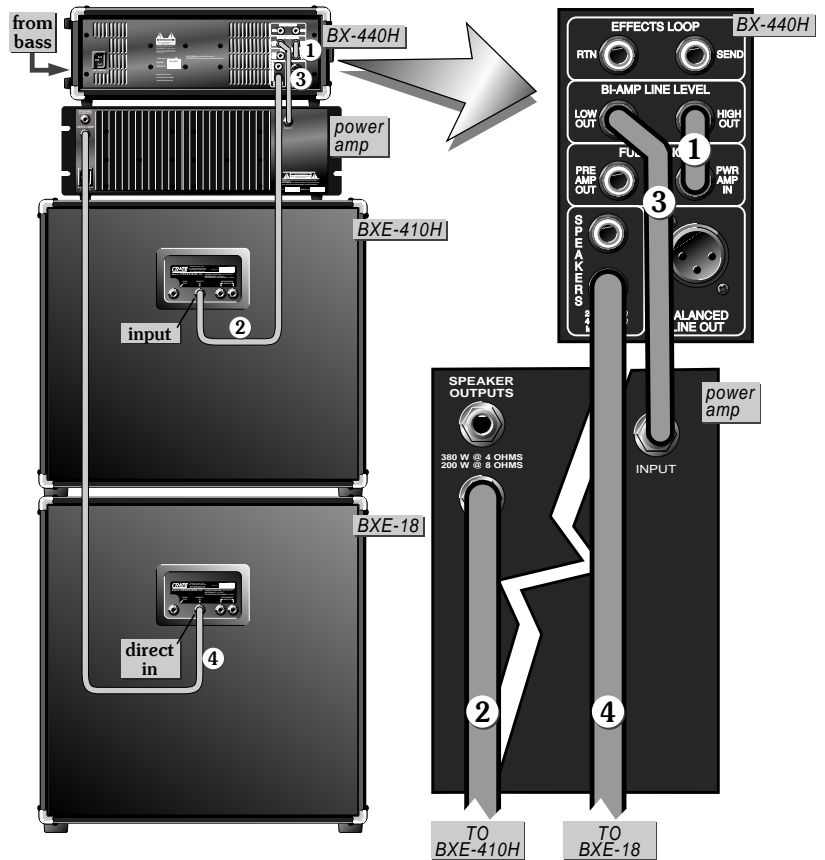

Example 3:

With the BX-440H and a BXE-18 cabinet for the low end; a BXE-210HP powered cabinet for the high end:

Plug your bass into the BX-440H, then:

- (1) Run a shielded cable from the **biamp low out** jack of the BX-440H to its **power amp in** jack.
- (2) Run a speaker cable from the **speaker out** jack of the BX-440H to the **input** jack of the BXE-18.
- (3) Run a shielded cable from the **biamp highout** jack of the BX-440H to the **input** jack of the BXE-210HP.

Adjust the Crossover Frequency and Balance controls for the best sound.

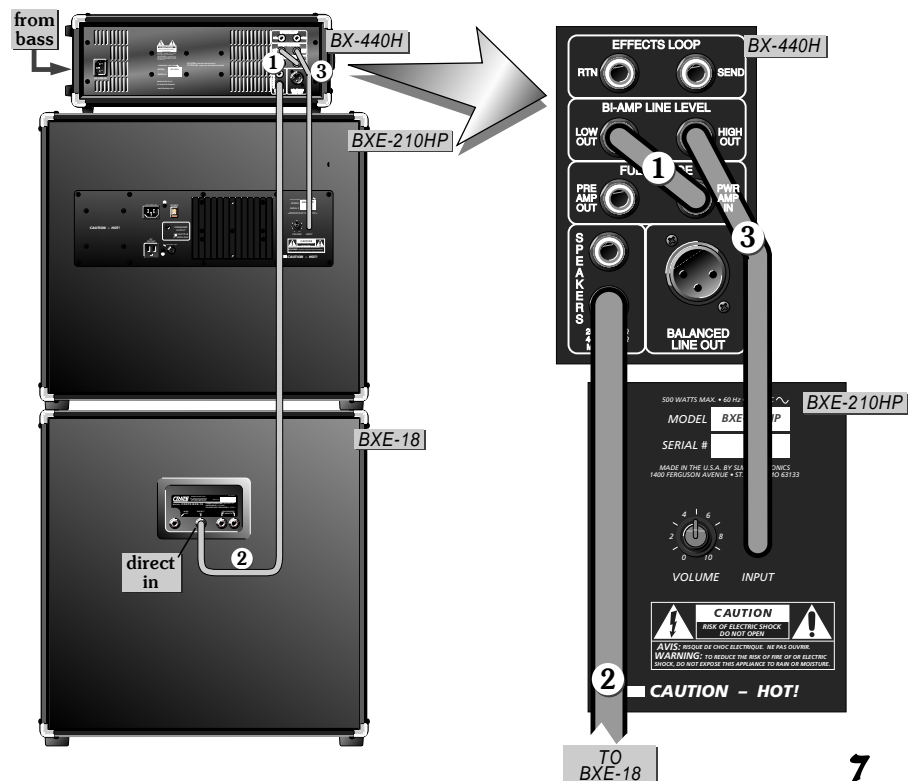

Using the Biamp Capabilities – BX-4115:

Example 1:

With the BX-4115 for the low end; a BX-220H and a BXE-410H cabinet for the high end:

Plug your bass into the BX-4115, then:
 (1) Run a shielded cable from the **biamp low out** jack of the BX-4115 to its **power amp in** jack. (Connection to the BX-4115's speaker is already made through the factory-installed speaker out cable.)

(2) Run a shielded cable from the **biamp high out** jack of the BX-4115 to the **power amp in** jack of the BX-220H.

(3) Run a speaker cable from the **speaker out** jack of the BX-220H to the **input** jack of the BXE-410H.

Adjust the Crossover Frequency and Balance controls for the best sound.

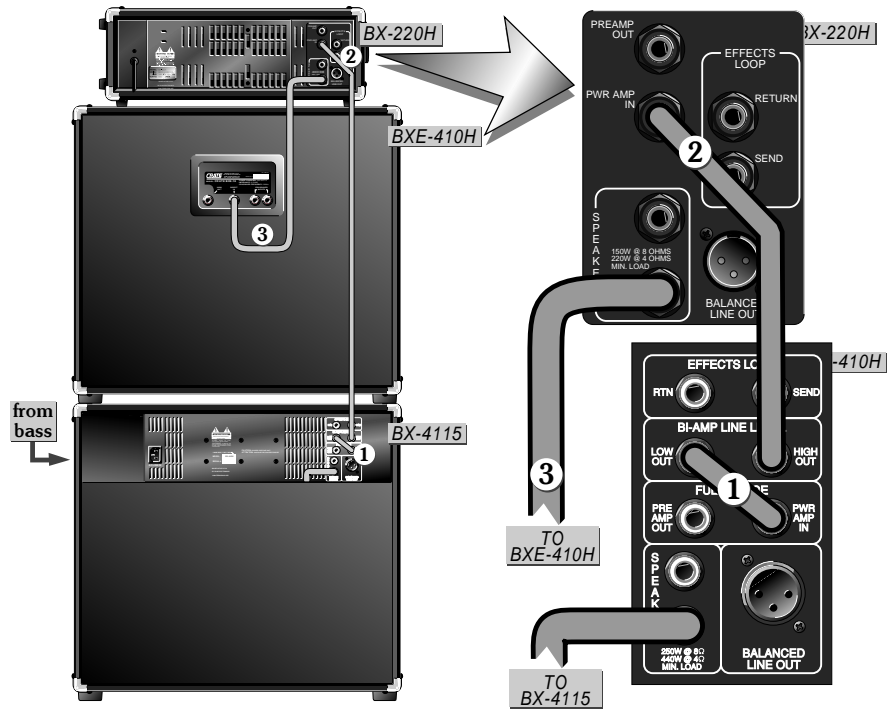

Example 2:

With the BX-4115 for the low end; a BX-2115 for the high end:

Plug your bass into the BX-4115, then:
 (1) Run a shielded cable from the **biamp low out** jack of the BX-4115 to its **power amp in** jack. (Connection to the BX-4115's speaker is already made through the factory-installed speaker out cable.)

(2) Run a shielded cable from the **biamp high out** jack of the BX-4115 to the **power amp in** jack of the BX-2115. (Connection to the BX-2115's speaker is already made through the factory-installed speaker out cable.)

Adjust the Crossover Frequency and Balance controls for the best sound.

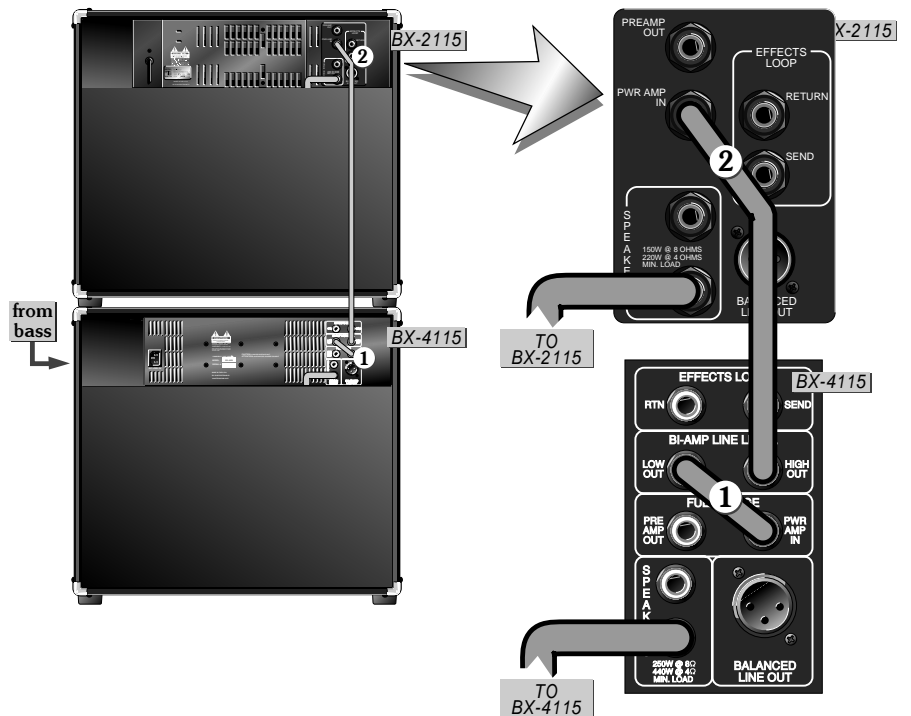

Using the Biamp Capabilities – BX-4115 (con't):

Example 3:

With the BX-4115 for the low end; a BX-210HP powered cabinet for the high end:

Plug your bass into the BX-4115, then:

(1) Run a shielded cable from the **biamp low out** jack of the BX-4115 to its **power amp in** jack. (Connection to the BX-4115's speaker is already made through the factory-installed speaker out cable.)

(2) Run a shielded cable from the **biamp high out** jack of the BX-4115 to the **input** jack of the BXE-210HP.

Adjust the Crossover Frequency and Balance controls for the best sound.

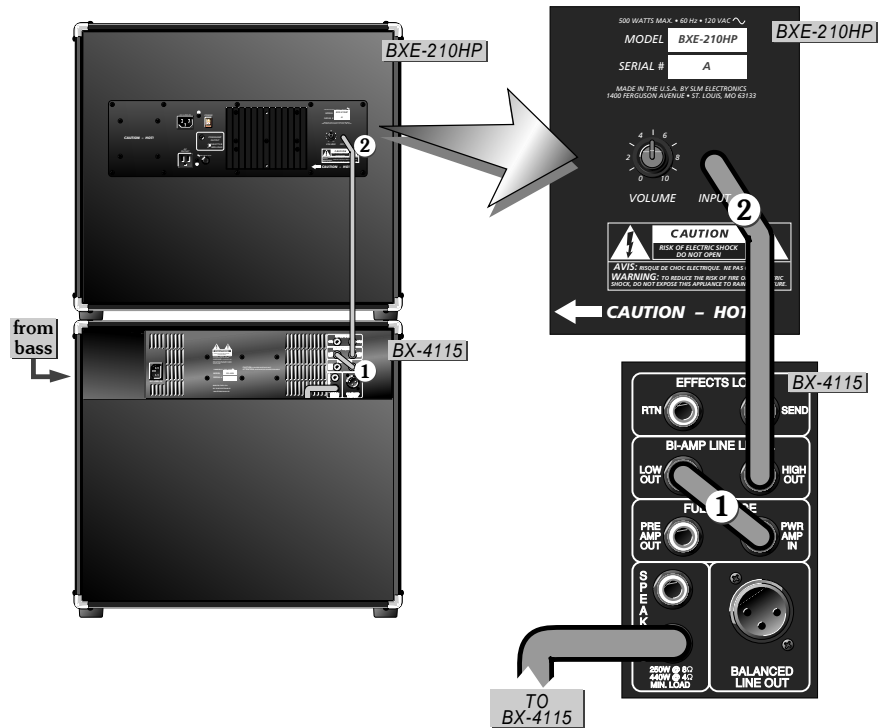

CRATE BX-440H / BX-4115 ThunderBass Amplifier

Some Suggested Settings:

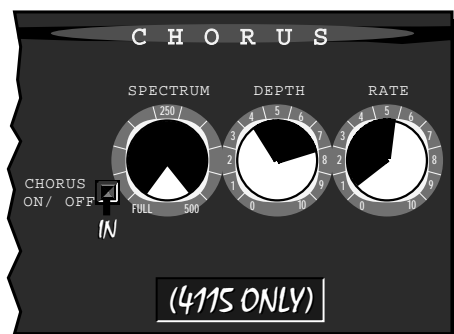
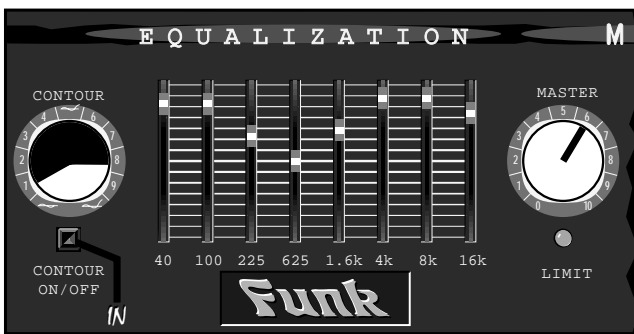
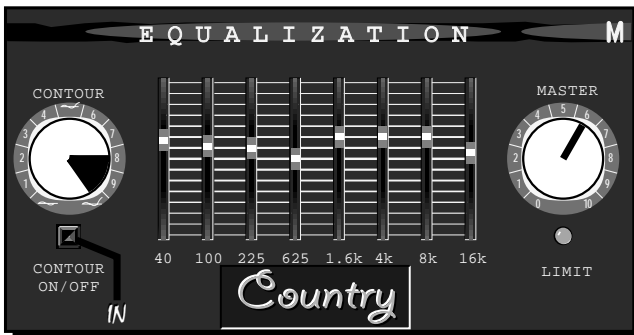
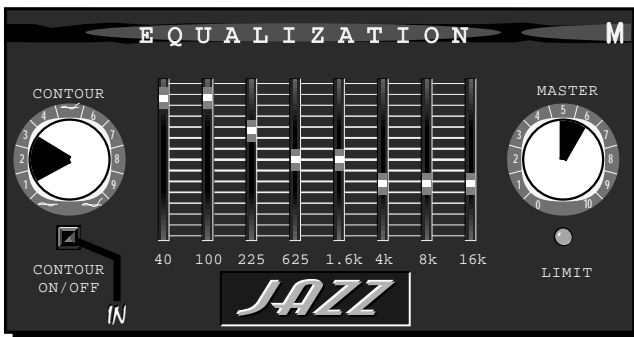
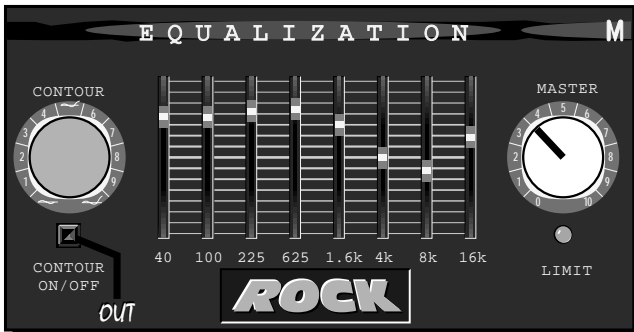

System Block Diagram:

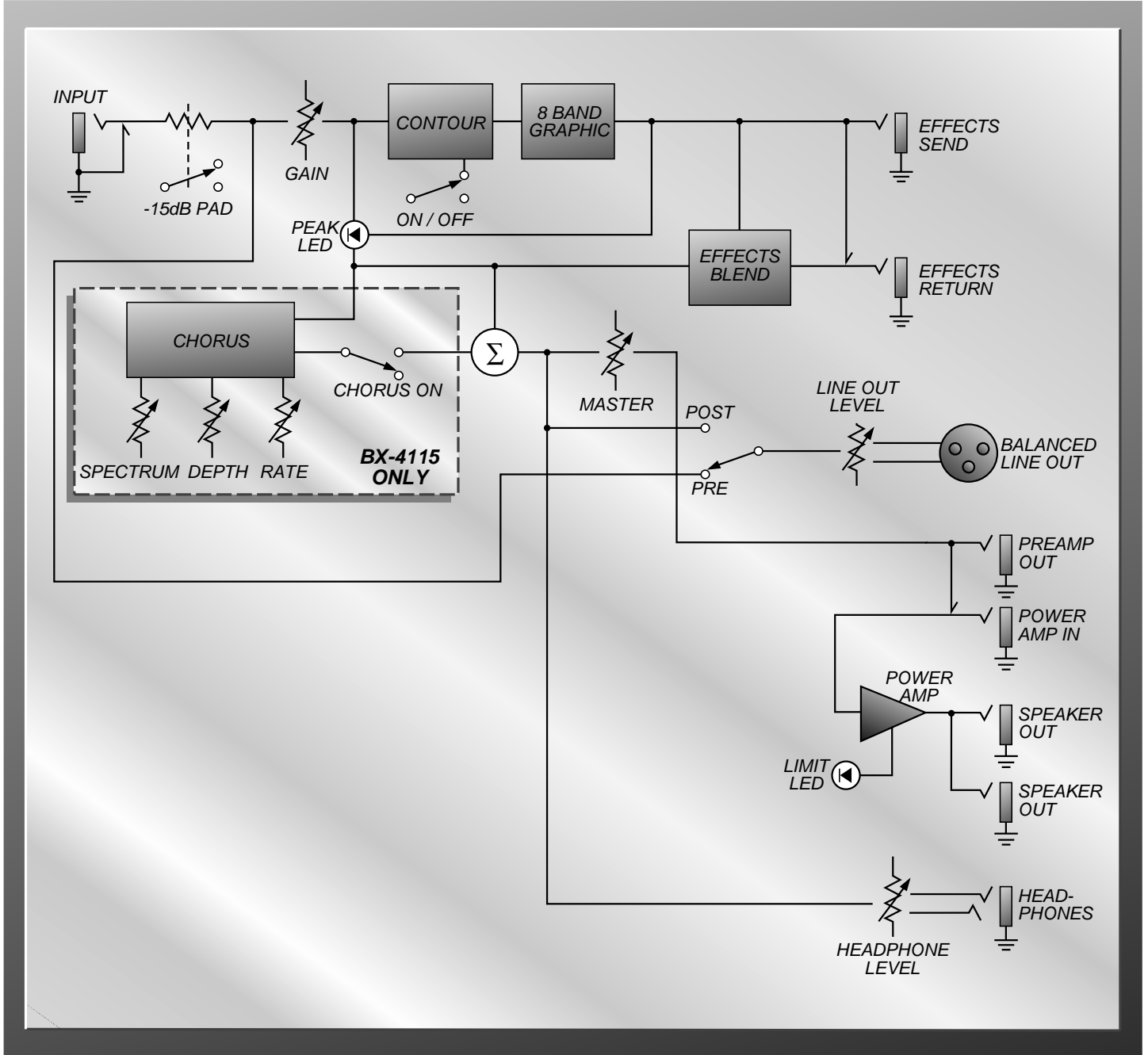

CRATE BX-440H / BX-4115 ThunderBass Amplifier

Technical Specifications:

Maximum Input Signal Level Accepted	17 volts peak to peak (-15dB switch pressed in)
Input Power Requirements	120VAC, 60Hz, 1200 watts max.
Input Impedance	500k ohms (-15dB switch out), 75k ohms (-15dB switch in)
Signal to Noise Ratio	75dB typical
Output Power Rating	250 watts RMS @ < 5% THD w/8 ohm load, 120VAC line 440 watts RMS @ < 5% THD w/4 ohm load, 120VAC line
Gain @ 1kHz	67dB with EQ flat, Contour off
EQ Section	20dB range (± 10 dB) @ 40Hz, 100Hz, 225Hz, 625Hz, 1.6kHz, 4kHz, 8kHz and 16kHz
Internal Speaker	
Size/Type	15" ThunderBass
Magnet	56 oz
Voice Coil	3"
Impedance	8 ohms
Size and Weight, BX-440H	7-1/8"H ¹ x 19-1/2"W ¹ x 15-1/4"D, 42lbs.
Size and Weight, BX-4115	23-5/8"H ² x 24"W x 15-3/4"D, 87lbs.

¹including rubber feet

²without casters installed; casters add 1-3/4" to height

CRATE continually develops new products, as well as improves existing ones. For this reason, specifications and information in this manual are subject to change without notice.



MUSICIAN MADE IN THE U.S.A. by

CRATE

CRATE/SLM ELECTRONICS, A DIVISION OF ST. LOUIS MUSIC, 1400 FERGUSON AVENUE, ST. LOUIS, MO 63133

47-593-01 • 06-96